

Lift with your fingertips

Heben mit Fingerspitzengefühl



AirHandle e-p AB  
Förrådsgatan 7  
SE-6662 34 ÅMÅL  
SWEDEN

AirHandle e-p AB  
Cederdalsvägen 6 D  
SE-186 40 VALLENTUNA  
SWEDEN



*Investing in your future*



EUROPEAN  
UNION  
European Regional  
Development Fund

[www.air-handle.com](http://www.air-handle.com)



### SAFE HANDLING

**Max load:** Adjusted to correspond to gripper payload. Stops the lift at heavier loads.

**Gripper weight:** Controlling that releasing of goods cannot be done in mid-air.

**"GripOK"-signal:** Control to stop improperly gripped products from being lifted.

### CONTROL SYSTEM

Grip the handle and the lift tool follows your hand. It can't be easier!



Electronic controller with all functions for both lifting and gripper ensure easy and safe handling.

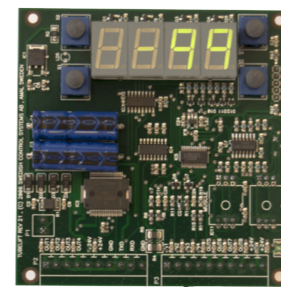

### GRIPPER TOOLS

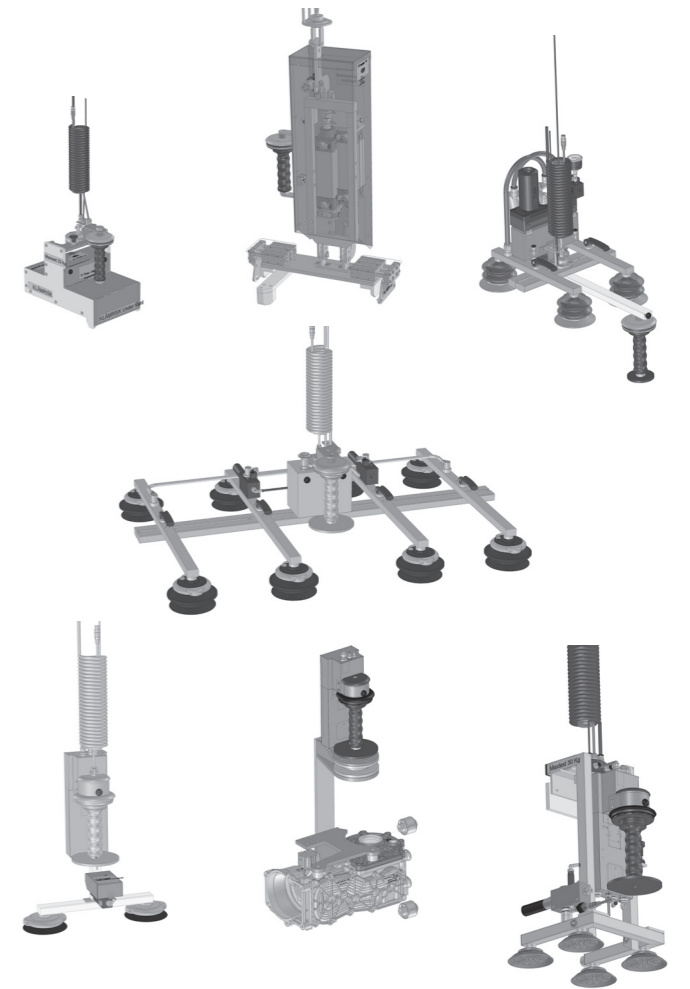

Customized to fit your handling. Adjustable max load and "GripOK"-signal. Can be operated in weightless balance mode.

### LIFTING EQUIPMENT

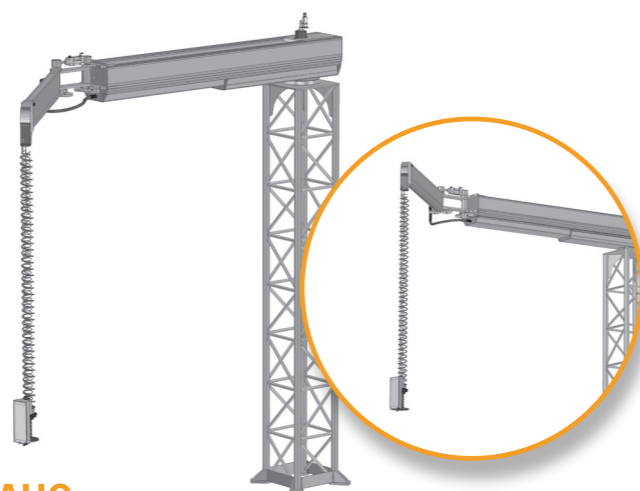

**AHC**  
Reach 6 m 360°.  
Fast easy installation.

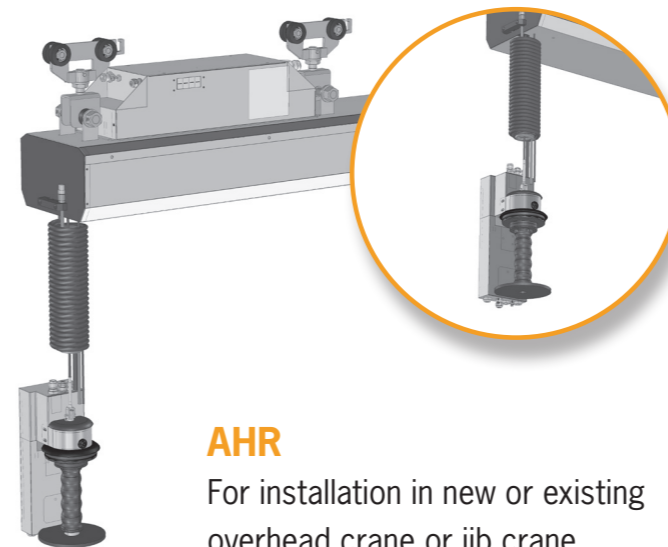

**AHR**  
For installation in new or existing overhead crane or jib crane.

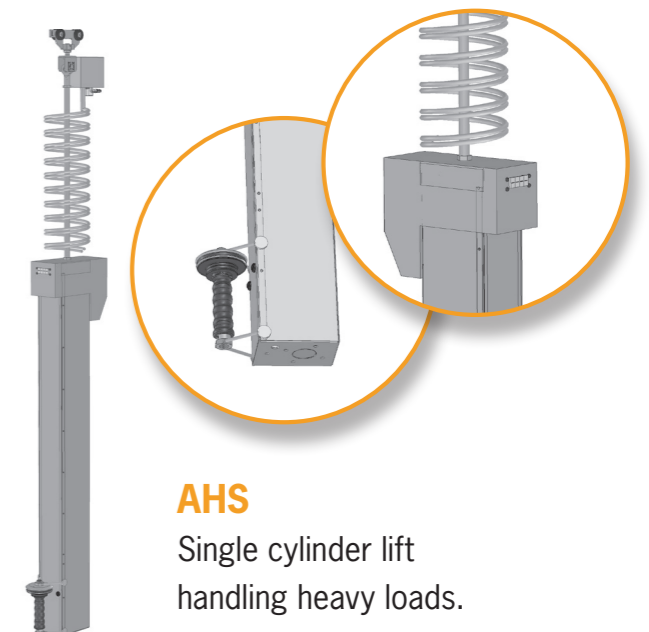

**AHS**  
Single cylinder lift handling heavy loads.